

FORM

Fancoil Units



 YERLİ
ÜRETİM

CE



FORM

55
YIL YEARS

About Form

Founded in 1965, FORM Group consists of 4 independent companies. The group aims to provide, central and individual air conditioning and industrial applications in the field of production and supply of devices that will improve the quality of life. Mainly Form provides energy efficient products to residences, hotels, schools, hospitals, all kinds of buildings, factory and air conditioning system solutions for shopping malls.

FORM MHI Klima Sistemleri A.Ş. offers a wide range of air conditioning products and system solutions under Mitsubishi Heavy Industries brand from VRF to split and multi split products.

FORM Endüstri Ürünleri A.Ş. specializes in centralized air conditioning system solutions. As the exclusive distributor of rooftop air conditioners of Lennox, heat pumps of Climate Master, cooling groups and chillers of Dunham Bush and CLIVET and ventilation systems of CVS, this company is the pioneer company of Turkey's HVAC industry.

FORM Endüstri Tesisleri A.Ş. , is the manufacturing company of the group and maintains its activities in İzmir Pancar Organized Industrial Zone. FORM Endüstri Tesisleri A.Ş. manufactures and sells industrial products such as evaporative coolers, natural daylight lighting systems, ventilation and smoke extraction covers.

In addition to these 3 companies within FORM Group, FORM Yönetim Destek ve Yatırım A.Ş. provides support to all companies in Marketing, Human Resources, Accounting & Finance, IT, Logistics, etc.

The head office of FORM Group is located in Maslak, Istanbul. In Ankara, Antalya, Izmir, Adana and Bursa there are regional offices.

FORM Group, which is a founding member of ISKID (HVAC Association) and ISKAV (HVAC Foundation), is also represented by personal memberships in foreign air conditioning associations such as ASHRAE and IGSHPA, and continues to be one of the serious, reliable and leading communities in the sector and in all areas where it serves, depending on the ethical values of the sector.



FORM Fancoil units preferred for high performance, efficiency, special design, quiet operation, durability, ergonomic dimensions and low maintenance costs. Application areas are hotels, offices, hospitals, business centers, administrative buildings, public buildings, residences, villas, residences and shopping malls.



FEATURES

- FORM Fan-Coil Units are available in 2 or 4 pipes configuration with 5 different models in each configuration.
- All units have CE certification.
- Special heat exchanger structure, it produces high efficiency solutions and low operating cost.
- In order to meet customer needs, a Windows operating system based selection software is used to determine the appropriate model for the desired indoor climate conditions and the capacity requirements.
- Form fancoils have elegant design thanks to their ergonomic dimensions and provide easy installation.
- It has flanges suitable for supply and return air duct connection.
- Silent operation with 3-speed adjustable fan and high-efficiency motor.
- Specially designed filters are offered as standard. It can be easily reach from the side or front, cleanable and long life.
- Drain pan is painted and there is 6 mm insulation. with Optionel extended drain pan for easy installation.
- The drain pan has bevel to prevent water from filling.
- Special air vent design that allows the air in the coil to be removed.
- The electrical connection is enclosed in a special box to prevent electrical leakage. All CE electrical tests of the units are done by factory.

Nomenclature

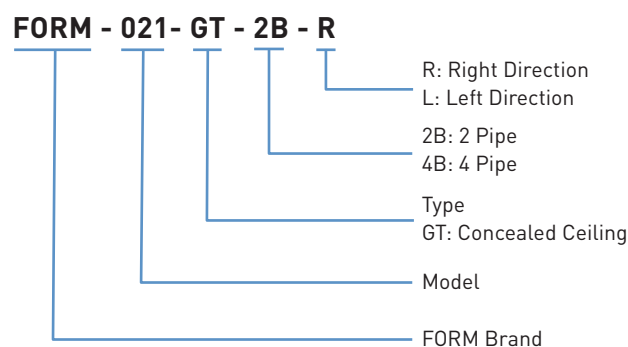

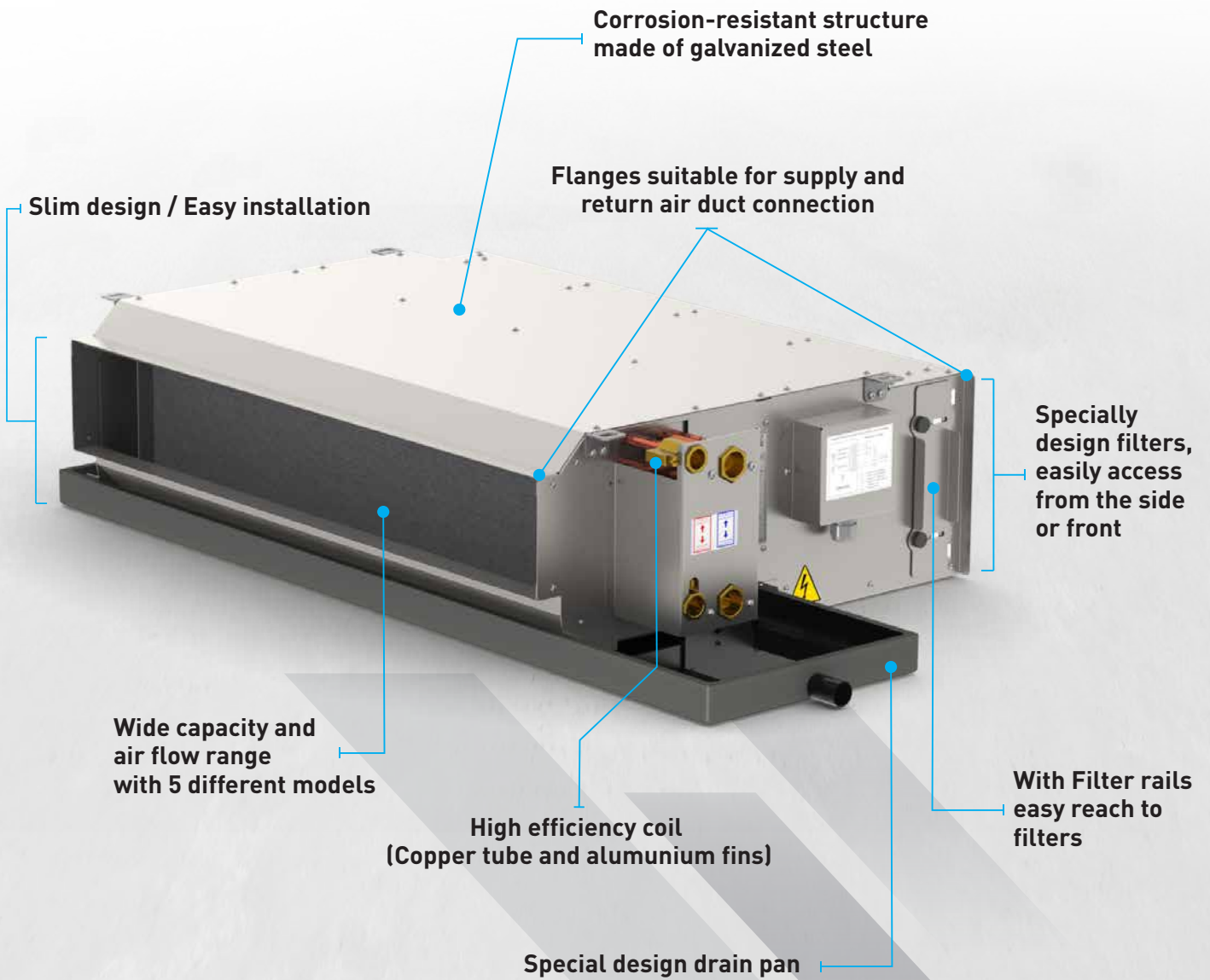

Technical Specifications

STRUCTURE

- The structure consists of 0.8 - 1 mm thick galvanized steel and is resistant to corrosion.
- The interior of the unit is covered with 3 mm thick polyethylene based insulation material. This material is it also provides sound insulation.
- The unit have factory installed mounting brackets.

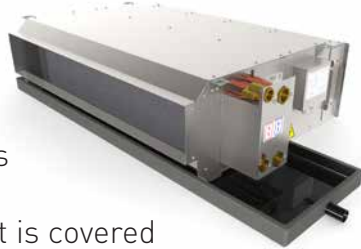

COIL

- The coil consisting of copper pipes and aluminum fins is designed for 2 and 4 pipe systems and has high thermal efficiency.
- Coils are tested at 35 bar pressure.
- Water inlet-outlet connections are suitable for 3/4" pipe connection for cooling and 1/2" pipe connection for heating.
- There is a protection plate on the collector side of the coils to prevent damage to copper pipes.

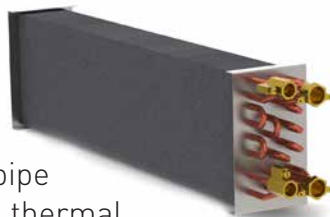

DRAIN PAN

- The "inside" of the condensation tray, which is manufactured as a single piece by pressing in a press made of 1 mm thick sheet metal material, is coated in a way to prevent rust.
- The interior of the "U" shaped ceiling is inclined to prevent water accumulation and provides easy evacuation of the accumulated water.
- The bottom of the ceiling is completely covered with 6mm thick rubber-based insulation material to prevent condensation to form on the outer surface.



EXTENDED DRAIN PAN (Optional)

- Extended drain pan accessory should be used to ensure that condensation on the installation elements such as valves and strainers is collected into the drain pan.
- The width of extended drain pan is the same as the width of the original pan and its length is 24 cm.



FAN

- In FORM Fancoil, double suction, forward curved blades, high efficiency fans are used.
- Depending on the unit size, 1 to 4 fans are used in one unit.



MOTOR

- Monophase and 3 speed motors are used in all units.
- Sound level is low, energy efficiency is high.
- The shafts of the motors are specially coated against corrosion.



FILTER

- Specially designed slider filters can be easily removed and installed from the side covers or the front by applying them through the slides.
- In large models, 2 or 3 pieces of filters are used and they are attached to each other by special interlocking pieces.



2 Pipe Duct Type Fancoil

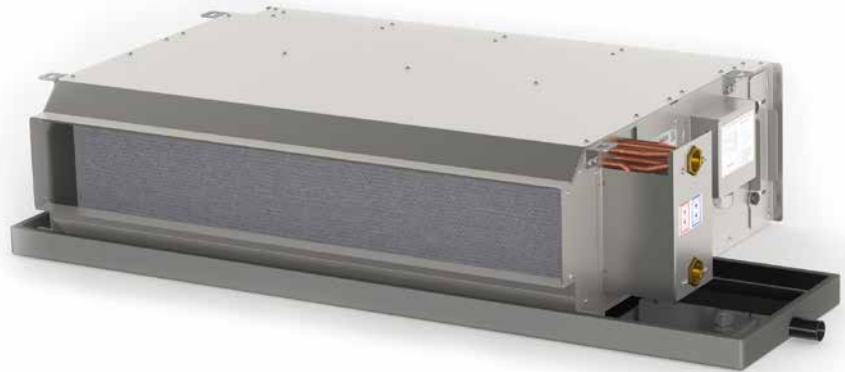

MODEL			FORM-021	FORM-042	FORM-062	FORM-083	FORM-104
Total Cooling Capacity		kW	2,56	4,80	5,90	8,03	11,99
Sensible Cooling Capacity			2,12	3,97	4,79	6,43	9,78
Total Heating Capacity			6,17	11,50	13,83	18,38	28,72
Power Usage		W	61,6	113	129,5	174,6	259
Air volume	L	m ³ /h	396	752	908	1119	1768
	M		500	966	1168	1443	2260
	H		598	1160	1400	1660	2640
Water Flow	Cooling	m ³ /h	0,44	0,82	1,01	1,38	2,06
	Heating		0,53	0,99	1,19	1,58	2,47
Sound Pressure Level	L	db(A)	33,6	35,1	37,2	38,3	40,6
	M		40,7	41,8	43,3	44,8	46,2
	H		45,1	46,0	47,9	49,2	51,2
NR	L		30	29	30	31	32
	M		35	38	39	38	39
	H		38	42	44	43	44
NC	L		27	27	28	29	30
	M		34	36	38	37	37
	H		37	40	43	42	43
Water Pressure Drop	Cooling	kPa	13,9	22,6	36,4	31,6	27,6
	Heating		17,3	27,7	35,2	34,2	32,1
Number of Rows			3	3	3	3	3
Water Connection Size			3/4"	3/4"	3/4"	3/4"	3/4"
Voltage / Frequency /Phase			230 V/ 50 Hz / 1 ph				
Weight		kg	14,8	22,1	23,6	33,4	46,2

L: Fan Low
M: Fan Medium
H: Fan High

*All air volumes according to 0 PA External Pressure.

*Cooling: Air Inlet at 27°C/19 °C KT/YT , Water Inlet at 7°C/12 °C

*Heating: Air Inlet at 20°C/15 °C KT/YT , Water Inlet at 70°C/60 °C

4 Pipe Duct Type Fancoil



MODEL			FORM-021	FORM-042	FORM-062	FORM-083	FORM-104
Total Cooling Capacity		kW	2,51	4,64	5,78	7,83	11,59
Sensible Cooling Capacity			2,08	3,82	4,68	6,26	9,42
Total Heating Capacity			2,65	4,90	5,72	8,26	12,51
Power Usage		W	61,6	113	129,5	174,6	259
Air volume	L	m³/h	383	720	872	1050	1652
	M		488	926	1126	1338	2128
	H		580	1100	1350	1604	2510
Water Flow	Cooling	m³/h	0,43	0,8	0,99	1,34	1,99
	Heating		0,23	0,42	0,49	0,71	1,08
Sound Pressure Level	L	db(A)	33,6	35,1	37,2	38,3	40,6
	M		40,7	41,8	43,3	44,8	46,2
	H		45,1	46,0	47,9	49,2	51,2
NR	L		30	29	30	31	32
	M		35	38	39	38	39
	H		38	42	44	43	44
NC	L		27	27	28	29	30
	M		34	36	38	37	37
	H		37	40	43	42	43
Water Pressure Drop	Cooling	kPa	13,4	21,3	35	30,2	30,7
	Heating		8,1	33,8	8,5	19,6	52,4
Number of Rows			3+1	3+1	3+1	3+1	3+1
Water Connection Size			3/4" - 1/2"	3/4" - 1/2"	3/4" - 1/2"	3/4" - 1/2"	3/4" - 1/2"
Voltage / Frequency / Phase			230 V/ 50 Hz / 1 ph				
Weight		kg	15,3	22,9	24,7	34,3	48,1

L: Fan Low
M: Fan Medium
H: Fan High

*All air volumes according to 0 PA External Pressure.

*Cooling: Air Inlet at 27°C/19 °C KT/YT , Water Inlet at 7°C/12 °C

*Heating: Air Inlet at 20°C/15 °C KT/YT , Water Inlet at 70°C/60 °C

*Sound Test Conditions at 21° Room Temperature, % 42 RH, Dry Coil Conditions According to ISO 3745.

Dimensions

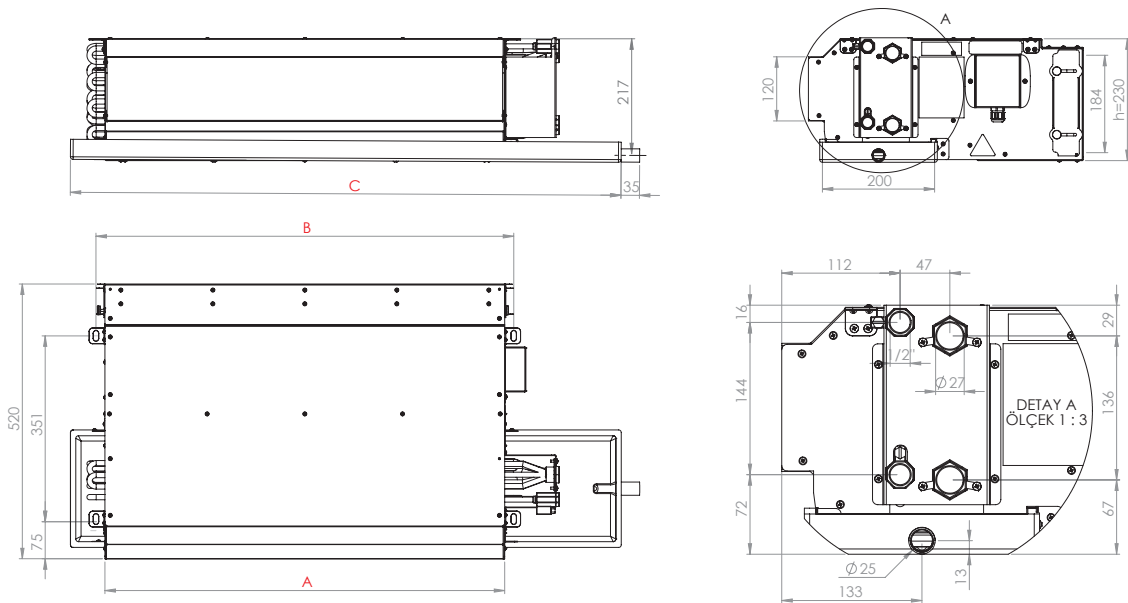
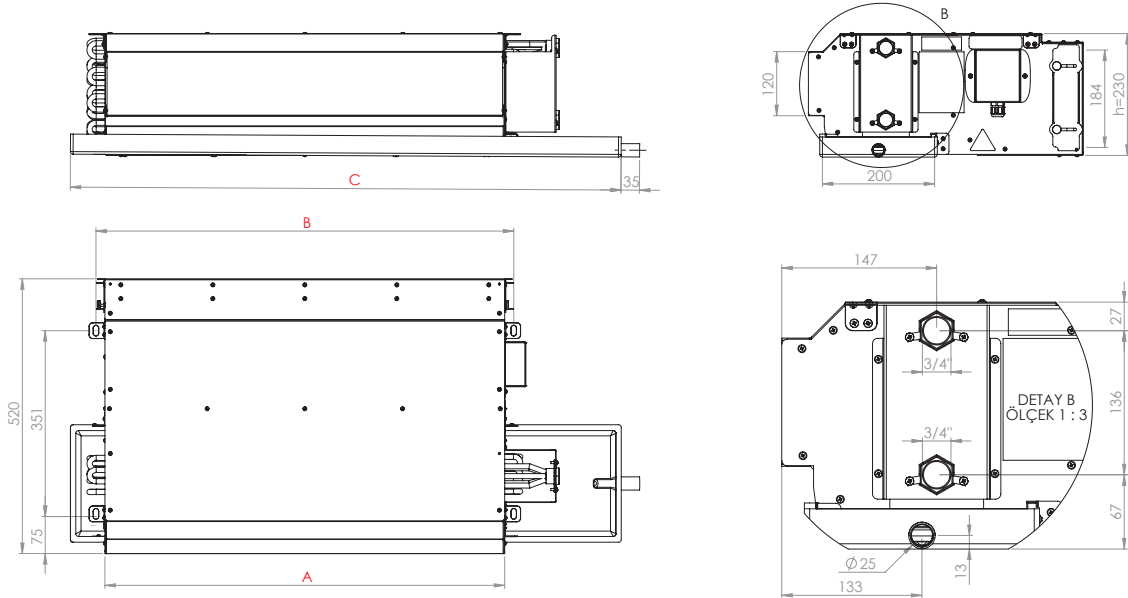

MODEL			FORM-021	FORM-042	FORM-062	FORM-083	FORM-104
Dimensions	A	mm	455	755	885	1155	1605
	B	mm	489	789	919	1189	1639
	C	mm	660	960	1090	1360	1810
	h	mm	230	230	230	230	230

2 Pipe Cassette Type Fancoil

4-Way Compact Cassette Type



General Features

- Eshtetic ve Quiet design.
- Compact Four way cassette : Extremely compact casing suits any room's decor and requires little space for installation on a low ceiling.
- Due to compact body and light weight, all models can be installed without a hoist.
- 360°air supply panel is standard for compact 4-way cassette.
- Quiet operation thanks to advanced 3D spiral fan design.
- Standard built-in drain pump with 500 mm pump head for compact size.
- Wide air flow range with 3 speed motor.
- Standart cleanable filters

MODEL			300	400	500
Total Cooling Capacity ⁽¹⁾	kW		3	3,7	4,5
Total Heating Capacity ⁽²⁾	kW		6,8	8,7	10,3
Air Volume	m ³ /h		560	690	850
Water Flow	m ³ /h		0,5	0,6	0,8
Water Pressure Drop	kPa		14	15	16
Water Connection Size	inch		3/4"	3/4"	3/4"
Weight	Unit	kg	16,5	16,5	16,5
	Panel	kg	2,5	2,5	2,5
Dimensions - Unit ⁽³⁾	Size	mm	575	575	575
	Width	mm	575	575	575
	Height	mm	261	261	261
Dimensions - Panel ⁽³⁾	Size	mm	647	647	647
	Width	mm	647	647	647
	Height	mm	50	50	50

4-Way Cassette Type



General Features

- Eshtetic ve Quiet design.
- Balanced air distribution with 4-way blower.
- Effective comfort in areas higher than 3 meters (high speed).
- Different swing angles for opposite covers.
- Easy installation and maintenance with ultra thin design (23-30 cm).
- Quiet operation thanks to advanced 3D spiral fan design.
- Standard built-in drain pump with 750 mm pump head .
- Standard cleanable filter.
- All operating and fault parameters from the digital display of monitoring.

MODEL			600R	750R	850R	950R	1200R	1500R
Total Cooling Capacity ⁽¹⁾	kW		5,7	7	7,5	8,2	10,4	12,9
Total Heating Capacity ⁽²⁾	kW		16,5	19,7	21	23,5	29,9	30
Air Volume	m ³ /h		1024	1267	1460	1600	2000	2550
Water Flow	m ³ /h		1	1,2	1,3	1,4	1,8	2,2
Water Pressure Drop	kPa		23,8	25,2	27	31,2	38	40
Water Connection Size	inch		3/4"	3/4"	3/4"	3/4"	3/4"	3/4"
Weight	Unit	kg	25	25	30,5	30,5	30,5	31,8
	Panel	kg	6	6	6	6	6	6
Dimensions - Unit ⁽³⁾	Size	mm	840	840	840	840	840	840
	Width	mm	840	840	840	840	840	840
	Height	mm	230	230	300	300	300	300
Dimensions - Panel ⁽³⁾	Size	mm	950	950	950	950	950	950
	Width	mm	950	950	950	950	950	950
	Height	mm	45	45	45	45	45	45

Selection Conditions Applicable to Tables

1 Air inlet conditions = 27°C / 47% humidity - water inlet temperature = 7°C and water temperature difference = 5°C

2 Air inlet conditions = 20°C - water inlet temperature = 7°C, ΔT = 10°C

3 Dimensions are for reference only. See the assembly booklet for details.

4 Pipe Cassette Type Fancoil

4-Way Compact Cassette Type



General Features

- Eshtetic ve Quiet design.
- Compact Four way cassette : Extremely compact casing suits any room's decor and requires little space for installation on a low ceiling.
- Due to compact body and light weight, all models can be installed without a hoist.
- 360°air supply panel is standard for compact 4-way cassette.
- Quiet operation thanks to advanced 3D spiral fan design.
- Standard built-in drain pump with 500 mm pump head for compact size.
- Wide air flow range with 3 speed motor.
- Standart cleanable filters

MODEL			300S	400S	500S
Total Cooling Capacity ⁽¹⁾		kW	2,5	2,9	3,5
Total Heating Capacity ⁽²⁾		kW	3,7	4,6	5,1
Air Volume		m ³ /h	560	690	850
Water Flow		m ³ /h	0,4	0,5	0,6
Water Pressure Drop	Cooling	kPa	22	16	24
	Heating	kPa	17	23	27
Water Connection Size	Cooling	inch	3/4"	3/4"	3/4"
	Heating	inch	1/2"	1/2"	1/2"
Weight	Unit	kg	16,5	16,5	16,5
	Panel	kg	2,5	2,5	2,5
Dimensions - Unit ⁽³⁾	Size	mm	575	575	575
	Width	mm	575	575	575
	Height	mm	261	261	261
Dimensions - Panel ⁽³⁾	Size	mm	647	647	647
	Width	mm	647	647	647
	Height	mm	50	50	50

4-Way Cassette Type



General Features

- Eshtetic ve Quiet design.
- Balanced air distribution with 4-way blower.
- Effective comfort in areas higher than 3 meters (high speed).
- Different swing angles for opposite covers.
- Easy installation and maintenance with ultra thin design (23-30 cm).
- Quiet operation thanks to advanced 3D spiral fan design.
- Standard built-in drain pump with 750 mm pump head .
- Standard cleanable filter.
- All operating and fault parameters from the digital display of monitoring.

MODEL			600F	750F	850F	950F	1200F	1500F
Total Cooling Capacity ⁽¹⁾		kW	5,1	5,9	6,2	6,7	9,3	10,6
Total Heating Capacity ⁽²⁾		kW	6,7	7,9	8,1	8,7	11,7	12,7
Air Volume		m ³ /h	1150	1450	1480	1720	1867	2100
Water Flow		m ³ /h	0,9	1	1,1	1,2	1,6	1,8
Water Pressure Drop	Cooling	kPa	15	17	20	22	32	38
	Heating	kPa	35	39	40	42	48	55
Water Connection Size	Cooling	inch	3/4"	3/4"	3/4"	3/4"	3/4"	3/4"
	Heating	inch	1/2"	1/2"	1/2"	1/2"	1/2"	1/2"
Weight	Unit	kg	35	35	35	35	38	38
	Panel	kg	6	6	6	6	6	6
Dimensions - Unit ⁽³⁾	Size	mm	840	840	840	840	840	840
	Width	mm	840	840	840	840	840	840
	Height	mm	300	300	300	300	300	300
Dimensions - Panel ⁽³⁾	Size	mm	950	950	950	950	950	950
	Width	mm	950	950	950	950	950	950
	Height	mm	45	45	45	45	45	45

Selection Conditions Applicable to Tables

1 Air inlet conditions = 27°C / 47% humidity - water inlet temperature = 7°C and water temperature difference = 5°C

2 Air inlet conditions = 20°C - water inlet temperature = 7°C, ΔT = 10°C

3 Dimensions are for reference only. See the assembly booklet for details.

Accessories

THERMOSTATS

SM107 ELECTROMECHANICAL THERMOSTAT

- 220 V AC
- Temperature range from 10°C-30°C
- Cool / Heat / Off selector switch
- 3 stage fan speed
- Integrated NTC type temperature sensor
- Valve outlet suitable for 2 and 4 pipe systems
- Thermostatic fan control



SM2008FFS-L DIGITAL THERMOSTAT

- 220 V AC
- Stylish design, digital LCD display
- Blue backlight
- Surface mounting
- Temperature range from 5°C to 35°C
- Cool / Heat / Auto selection setting
- Manual / Automatic 3 stage fan speed
- Valve outlet suitable for 2 and 4 pipe systems
- Continuous or thermostatic models for fan
- Low temperature protection
- Hotel card or window contact application
- Working in case the energy is cut off and coming back
- Two different working options for heating output



SM2028FFN DIGITAL TOUCH THERMOSTAT

- 220 V AC
- Stylish design, digital LCD display
- Touch screen
- Energy saving mode
- Flush mounting
- Temperature range from 5°C to 35°C
- Cool / Heat / Auto selection setting
- Keylock
- Weekly programming feature
- Manual / Automatic 3 stage fan speed
- Valve outlet suitable for 2 and 4 pipe systems
- Working in case the energy is cut off and coming back
- Low temperature protection



SM3035 DIGITAL TOUCH THERMOSTAT (MODBUS COMMUNICATION)

- 220 V AC
- Stylish design, digital LCD display
- Touch screen
- 5 digital outputs
- 1 passive input
- MODBUS communication
- NTC external sensor connection
- Door or window contact connection
- Electric heater control
- Hotel card contact
- Led lighting
- Surface mounting
- Temperature range from 5°C to 35°C
- Cool / Heat / Auto selection setting
- Keylock
- Weekly programming feature
- Manual / Automatic 3 stage fan speed
- Valve outlet suitable for 2 and 4 pipe systems
- Working in case the energy is cut off and coming back
- Low temperature protection



MOTORIZED VALVES

WT-2131

- 2 way
- DN15 connection diameter for 1/2 "
- DN20 connection diameter for 3/4 "
- External thread connection
- PN16
- Brass body
- Maximum fluid temperature 100°C
- KVS value for 1/2 "1.7
- KVS value for 3/4 "2.8



WT-3131

- 3 way
- DN15 connection diameter for 1/2 "
- DN20 connection diameter for 3/4 "
- External thread connection
- PN16
- Brass body
- Maximum fluid temperature 100°C
- KVS value for 1/2 "1.7
- KVS value for 3/4 "2.8



WT-4131

- 3-way, 4-port
- DN15 connection diameter for 1/2 "
- DN20 connection diameter for 3/4 "
- External thread connection
- PN16
- Brass body
- Maximum fluid temperature 100°C
- KVS value for 1/2 "1.7
- KVS value for 3/4 "2.8
- Bypass in itself



Valve Engine:



- 220V
- ON / OFF control
- Valve open / closed indicator
- Thermal actuator
- Normally closed (NC)
- 1.8 Watt
- IP54

FORM ENDUSTRI URUNLERI

Form Endustri Urunleri is a sales and service company for Central Air Conditioning equipment. Form Endustri Urunleri provides equipment and also helps designers and investors in choosing the right system for their building due to long experience. The main desire is in creating high efficiency and Green Certified Buildings. The company provides various different kinds of central air conditioning units for any size and type of project. The main equipment provided are Rooftops, Heat Pumps units, Chillers, Cooling Towers, Fancoils and Air Handling units.

FORM ENDUSTRI URUNLERI TIC. A.S.

Eski Buyukdere Cad. Sumer Sokak No:1B
Ayazaga Ticaret Merkezi Kat:16
Maslak 34398 Istanbul
T : +90 212 286 18 38
F : +90 212 286 66 48
E : merkeziklima@formgroup.com
W : www.formgroup.com

REGIONAL DIRECTORATES

Adana : +90 322 881 00 11
Ankara : +90 312 220 10 30
Antalya : +90 242 317 11 20
Bursa : +90 224 249 95 26
Izmir : +90 232 459 02 70

FORM GROUP COMPANIES

FORM Group Companies, established in 1965, manufactures, imports, sells and services Air Conditioning and Industrial systems equipment, to improve the life and manufacturing quality of people and products. FORM Group Companies, offering high energy efficiency and environment friendly system solutions, is one of the leading companies in its field, respecting the environment and the ethical values.



Central Air-Conditioning Systems Sales and Service

Eski Buyukdere Caddesi, Sumer Sokak,
No: 1B, Ayazaga Ticaret Merkezi, Kat: 16,
Maslak 34398, Istanbul, Turkey
T : +90 (212) 286 18 38
E : merkeziklima@formgroup.com



VRF-Individual Air-Conditioning Sales and Service

Eski Buyukdere Caddesi, Sumer Sokak,
No: 1B, Ayazaga Ticaret Merkezi, Kat: 12,
34398 Maslak - Istanbul, Turkey
T : +90 (212) 286 08 73
E : mitsubishi-form@formgroup.com



Industrial Systems Manufacturing, Sale & Service

Pancar Organize Sanayi Bolgesi,
7. Cadde, No: 13, Ayrancilar Torbali,
Izmir, Turkey
T : +90 (232) 864 21 00
E : formfabrika@formgroup.com

Regional Offices

Adana

Ankara

Antalya

Bursa

Izmir